

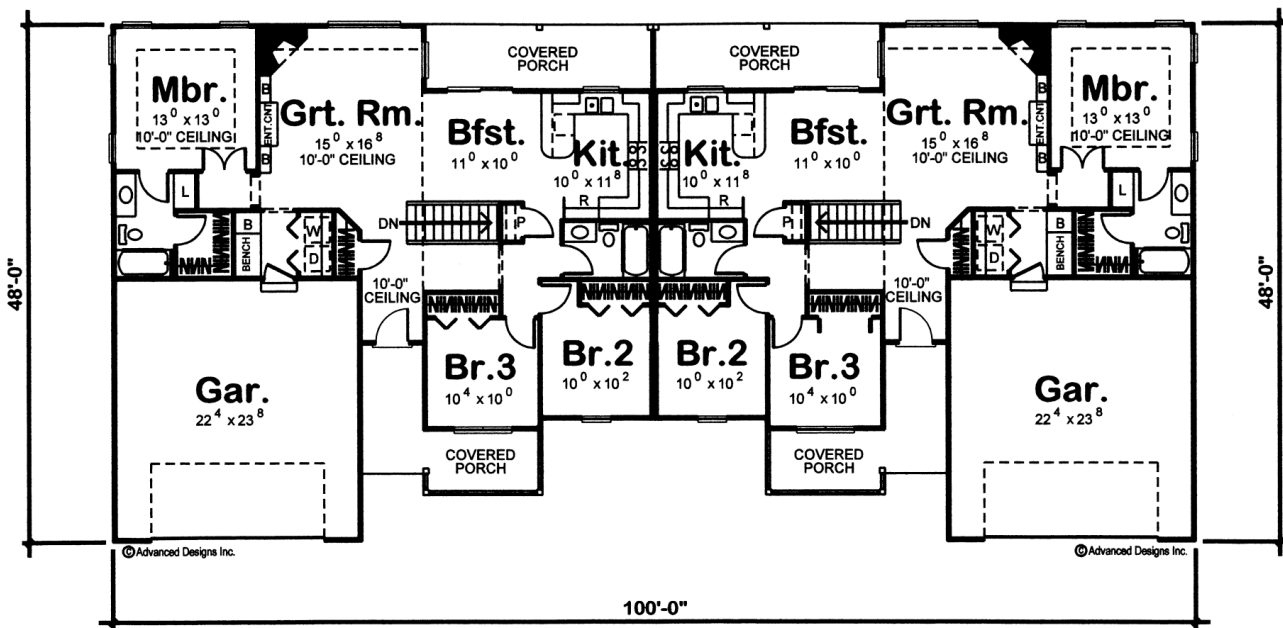

29176 - Callahan Data Sheet

1381 SQ FT	3 BEDS	2 BATHS	2 BAYS	100' 0" WIDE	48' 0" DEEP
---------------	-----------	------------	-----------	-----------------	----------------



Construction Specs

Layout

Bedrooms

Bathrooms	2
-----------	---

Garage Bays	2
-------------	---

Square Footage

Main Level	1381 Sq. Ft.
------------	--------------

Garage	550 Sq. Ft.
--------	-------------

Total Finished Area	1381 Sq. Ft.
---------------------	--------------

Exterior Dimensions

Width	100' 0"
-------	---------

Depth	48' 0"
-------	--------

Ridge Height	20'
--------------	-----

Calculated from main floor line

Default Construction Stats

Stats are unique to the individual plan.

Foundation Type	Basement
-----------------	----------

Exterior Wall Construction	2x4
----------------------------	-----

Roof Pitches	6/12 Primary, 10/12 Secondary
--------------	-------------------------------

Foundation Wall Height	9'
------------------------	----

Main Wall Height	9'
------------------	----

Plan Description

One of the most appealing aspects of this one-story, multi-family house plan, is its feeling of casual comfort, both inside and out. A deep, covered front porch offers a friendly welcome to family and friends. Inside, the entry hall opens to the great room, with its corner fireplace, built-in entertainment center and bookshelves, all beneath a 10-foot-high ceiling. Open to the great room, is the breakfast area and kitchen, with wrapping counter space and breakfast bar. The breakfast area accesses a wide, rear covered porch for outdoor dining options. The master suite is tucked away for privacy from the main living areas. It is brightened by plenty of natural light beneath a 10-foot-high ceiling in the bedroom, and a walk-in closet in the bath area. Secondary bedrooms 2 and 3 have views to the front and share a hall bath. A practical laundry area with bench also serves as a mud room between the great room and the 2-car-garage. As always any Advanced House Plans home plan can be customized to fit your needs with our alteration department. Whether you need to add another garage stall, change the front elevation, stretch the home larger or just make the home plan more affordable for your budget we can do that and more for you at Ahp. Unless you purchase an unlimited use license or a multi-use license you may only build one home from a set of plans. Plans cannot be re-sold.